



DAHAN QTZ160(6516)

HAMMERHEAD CRANE INTRODUCTION

# Content

Where QTZ160(6516) Use.....

What QTZ160(6516) Design .....

What QTZ160(6516) Specification.....

What QTZ160(6516) Advantage.....

QTZ160(6516) Outline Dimensions.....

Load Diagrams 10T.....

Masts.....

Anchorage.....

Mechanisms.....

Counter Weight.....

DAHAN Introduction.....

DAHAN Customers Case.....

160 6516

## Advantage

1. With 56,000 sets of market volume and excellent reputation, Dahan tower crane ranks the first place in China tower crane industry in the past decades. Dahan always adheres to the value that supply the most valuable tower crane and service for the customer, with the highest cost performance in the industry.



2. Dahan tower crane owns the leading technology R&D team, the product quality passed several experiments with strict testing. Otherwise, Dahan has 16 years of production technology and rich experiences in quality management. Till now, over 100 national technology patents of tower crane have been put into use already.



3. In order to guarantee the reliability of tower crane quality and reduce the cost, all raw materials are directly supplied by famous brands like Baosteel and Wisco. Raw materials for main parts such as standard section main limbs, tower caps adopt Q345B steel, thus the tensile strength increased by 30% and the tower crane becomes more safe and reliable.



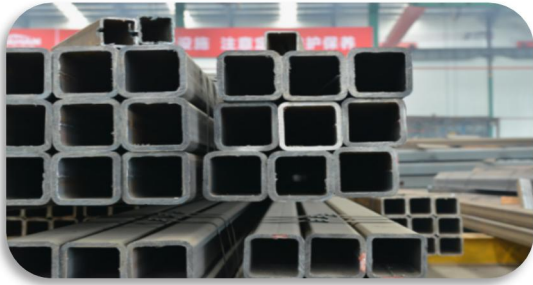

4. Dahan tower crane is the enterprise which firstly started to use the robot welding lines. At present, we have a fully automatic robot welding production line for mast sections fabrication made up by more than 100 welding robots. The production line is composed with automatic material preparation, welding and machining. All main parts of Dahan tower crane use robot welding, with the most advanced carbon dioxide mixed with argon gas shielded welding, it has deep depth of fusion, high quality of welding and stable performance.



5. All parts and components of Dahan tower crane use premium brands. Electric equipment with Schneider converter, aviation plug, stainless steel distribution box and three linkage console has features of low failure rate and easy installation.

Hoisting mechanism is provided by leading manufacturer Jiangte Motor or Dezhou Shengjian, all with engine oil, free maintenance, high reliability and low maintenance rate.

Slewing support uses Ma'anshan Fangyuan brand or Rothe Erde brand, twice tempering processing makes more smoothly operation and longer tower crane service life.



6. Attention to detail quality. High-strength bolt adopt shipborne scale DACROMET technology. It can keep not rusted for ten years .Swiss screw-thread bolts of preload promote 30 percent than traditional bolts. Weight limiter uses the tension ring structure and cast aluminum shell used Hoisting, derricking limiting stopper to extend service life.

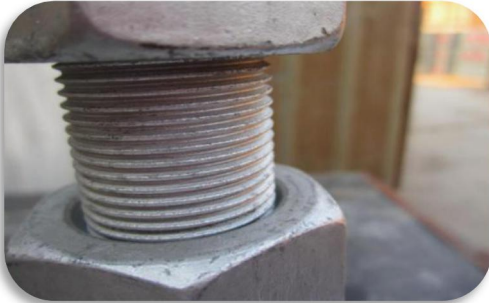

7.Large structures as mast section, turn able, top kit and hoisting jib adopt advanced equipment as NC machine tool, drilling machine, milling machine processing after welding. That effectively guarantees products assembly accuracy, reducing the failure rate and improving the security.



8.12 automatic spraying assembly line, the whole machine adopt impeller blasting to ensure the cleanliness of steel surface and eliminate the internal stress producing in welding process, increase the strength and steel surface hardness, increase painting adhesion. Two primer, a paint spraying technology, beautiful appearance, corrosion resistance has increased more than twice than the life of ordinary spraying process. Platform, the small car, fence and other small pieces adopt hot dip galvanized after acid phosphate treatment, rust resistance stronger.





9. Hoisting, derricking and slewing mechanism, with complete safety such as torque, weight limit. The steel wire rope broken rope device. Range of the car design against loss and broken shaft, such as tilting device. The electrical adopts overload protection, the design of PLC self-diagnosis system, it's convenient to maintenance.

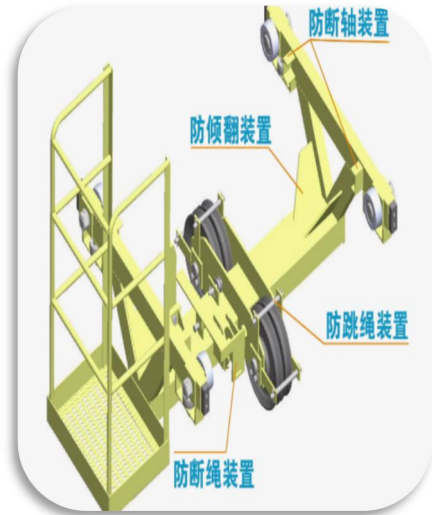





10. Dahan three production bases is Shandong, Hunan, Guangdong. Dahan tower crane are exported to more than 50 countries and regions. We have more than 1000 sets after-sales service network. We carried out the earliest stagnation point service mode in this tower crane industry that ensure the quality of service and efficiency. Otherwise, better to remove customer's worries.

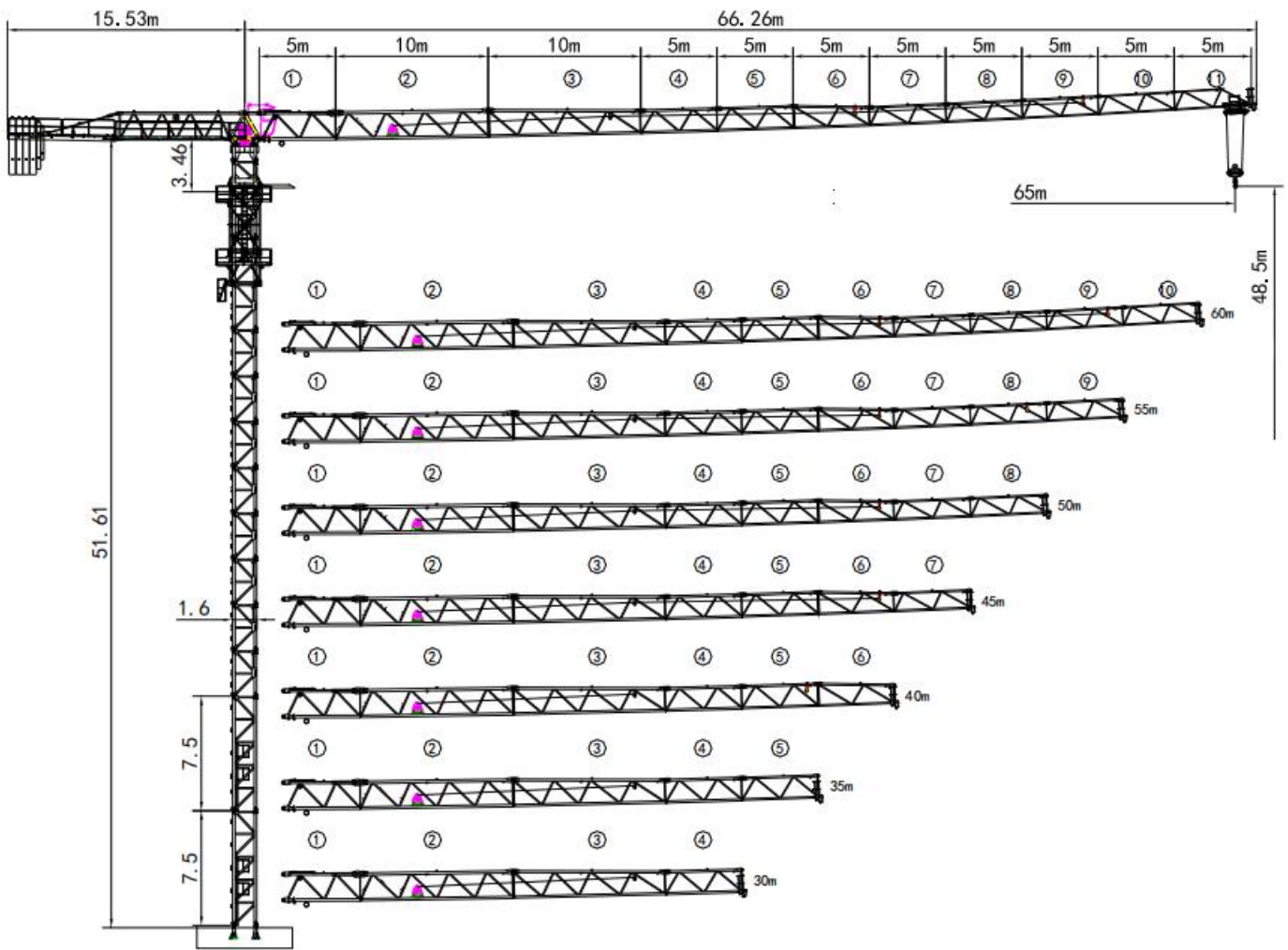





# QTZ160(6516) Outline Dimensions



### 65m





	(m)	3-17.2	18	20	22	24	26	28	30	31.8	32	34	36	
		4000										3960	3690	3440
Kg		8000	7590	6720	6020	5430	4940	4520	4160	3880	3850	3570	3330	
	(m)	38	40	42	45	48	50	52	55	58	60	62	65	
		3220	3020	2850	2610	2400	2280	2170	2010	1870	1790	1710	1600	
Kg		3110	2910	2740	2500	2290	2170	2060	1900	1770	1680	1600	1490	

### 60m





	(m)	3-20	22	24	26	28	30	32	34	36	37
		4000									
kg		8000	7170	6480	5910	5420	5000	4630	4310	4020	3890
	(m)	38	40	42	45	48	50	52	55	58	60
		3880	3650	3440	3160	2920	2780	2640	2460	2300	2200
kg		3760	3530	3330	3050	2810	2670	2530	2350	2190	2090



### 55m

	(m)	3-21.5	22	24	26	28	30	32	34	36
kg		4000								
		8000	7780	7040	6420	5900	5440	5040	4700	4390
	(m)	38	39.8	40	42	45	48	50	52	55
kg		4000		3980	3750	3450	3190	3040	2900	2700
		4110	3890	3860	3640	3340	3080	2930	2790	2590

### 45m/40/35/30m

	(m)	3-22.7	24	26	28	30	32	34
kg		4000						
		8000	7510	6850	6290	5810	5390	5020
	(m)	36	38	40	42	42.1	44	45
kg		4000					3800	3700
		4690	4400	4140	3900	3890	3690	3590

## Tower crane performance parameters

Use Level	U5	Maximum Installation Height of Wind Level	≤4					
Load State	Q2	Working state wind level	≤6					
Working Level	A5	Non-working state wind level	≤11					
Parameter Name	Unit	Value						
Rated Load Moment	t.m	160						
Max Load Capacity	t	8						
Max Rated Load Weight Allows Max Ratings	m	17.2						
Working Range (min / max)	m	3-65						
Lifting Height (fixed / attached)	t	1.6						
Rated Load Moment	m	48.5/200						
Hoisting	Hoisting speed	Fall	/		2		4	
		Speed	m/min	0~30	0~60	0~15	0~30	
		Load Capacity	t	4	2	8	4	
	Motor Model	/	YZDPE225L-8					
	Power	Kw	30					
	Motor Speed	r/min	720					
Slewing	Slewing Speed	r/min	0~0.7					
	Power	Kw	2*5.5					
	Speed	r/min	1450					
Trolley	Trolley Speed	m/min	0~65					
	Motor Model	/	YZR132-4					
	Power	kW	5.5					
	Speed	r/min	1435					
	Jacking Speed	m/min	0.5					
Jacking	Hydraulic System Rated Work	MPa	25					
	Motor Model	/	YEZS132m-4					
	Power	kW	7.5					
	Speed	r/min	1470					
	Hydraulic Cylinder by / piston Rod	mm	160/110					
	Counterweights	Load Radius	m	65	55	45		
Counter Weight		t	17.5	15.9	14.2			
Power	Kw	53.5						

## Tower Crane Mechanism Configuration Parameters

	Name		Unit	
	Hoist mechanism	Motor	Model	/
Power			Kw	30
Speed			r/min	720
		Brake Torque	m	630-1250
Reducer		Speed Ratio	/	17.2
Wire Rope		6×36WS+FC- φ 14-1770-I-		
2 times the lowest rate of steady decline≤9m/min				
Slewing mechanism	Motor	Model	/	YTRVFW132M14F1/F2
		Power	Kw	2*5.5
		Speed	r/min	1450
	Reducer	Model	/	JH13
		Speed Ratio	/	162
		Output Torque	N.m	9000
	Output gear parameters	Modulus	M	10
		Gear Number	Z	13
		Displacement Coefficient	X	+0.5
Slewing ring	Single Row Four Point Contact Ball	Model	/	QWA1390.50
		Modulus	M	10
		Gear Number	Z	157
		Displacement Coefficient	X	+0.75
Trolley mechanism	Motor	Model	/	YPBE132-4
		Power	Kw	5.5
		Speed	r/min	1450
	Reducer	Speed Ratio	/	40.7
	Wire Rope	6×19W+FC-7.7-1670-II		
Jacking system	Motor	Model	/	Y132M-4
		Power	Kw	7.5
		Speed	r/min	1470
	Hydraulic Power Station	Flow	L/min	14
		Working Pressure	Mpa	25



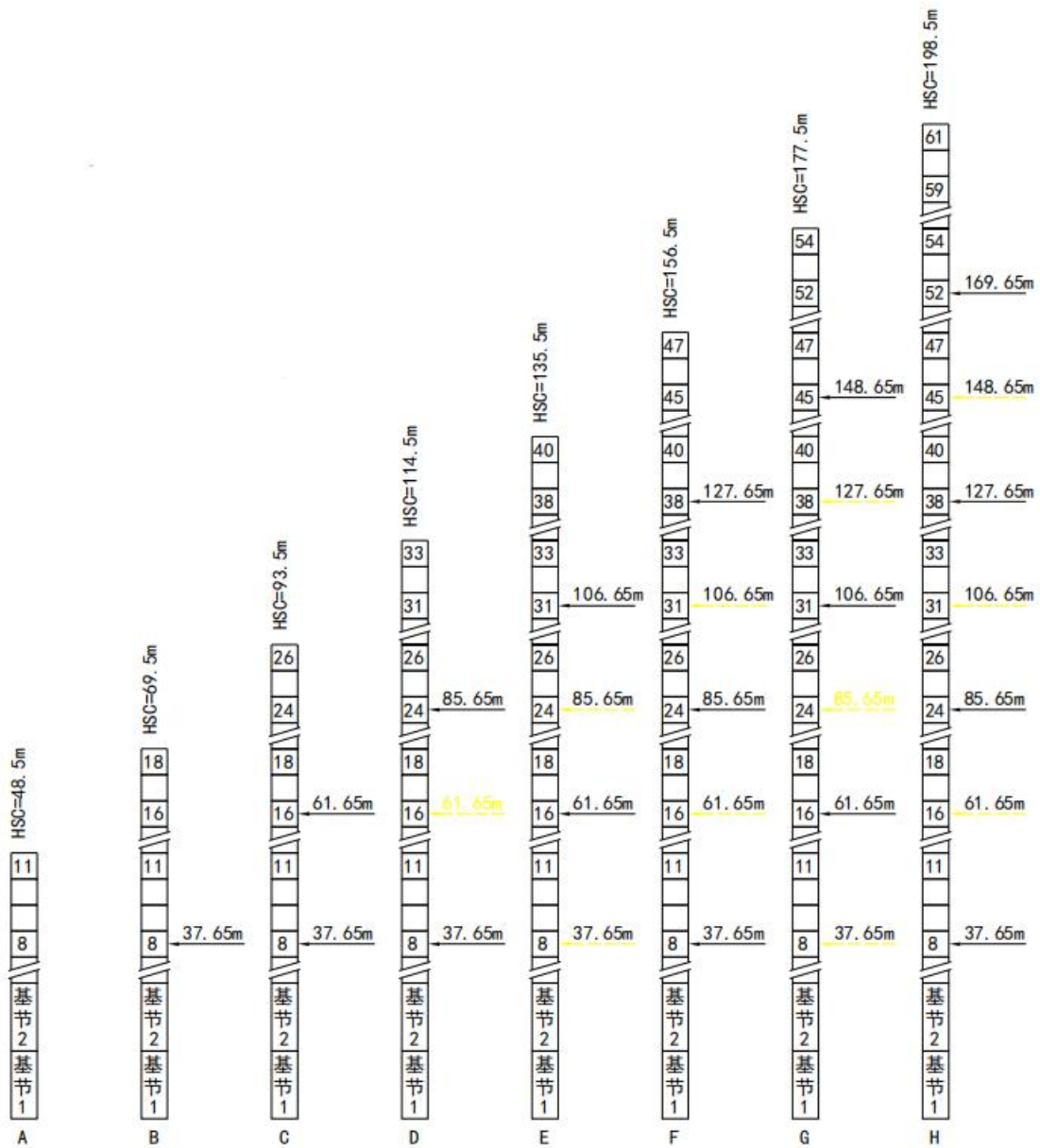

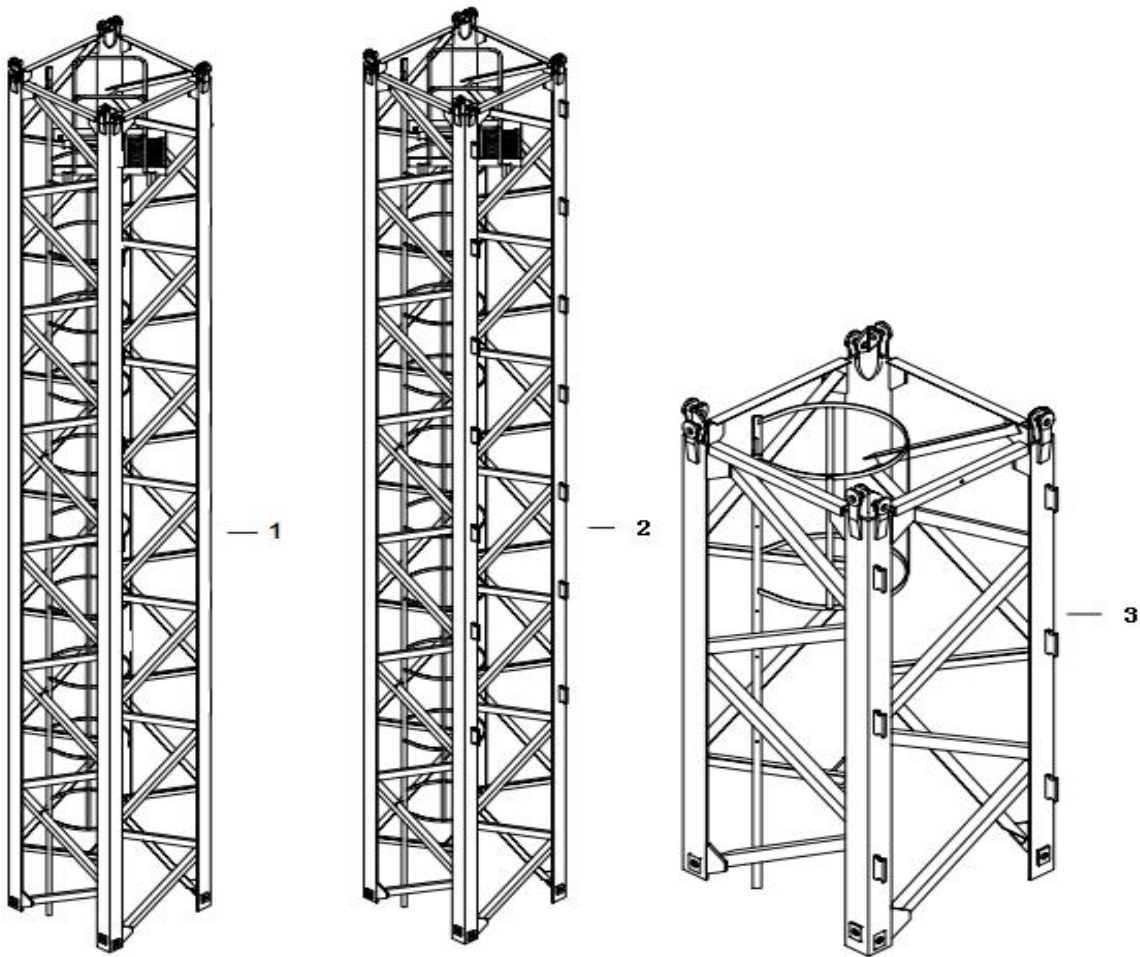

	A	B	C	Weight
	mm	mm	mm	Kg
<b>Base Section 1</b>	<b>1730</b>	<b>1670</b>	<b>7760</b>	<b>3480</b>
<b>Section 3</b>	<b>1700</b>	<b>1700</b>	<b>3260</b>	<b>1180</b>

## Climbing Cage

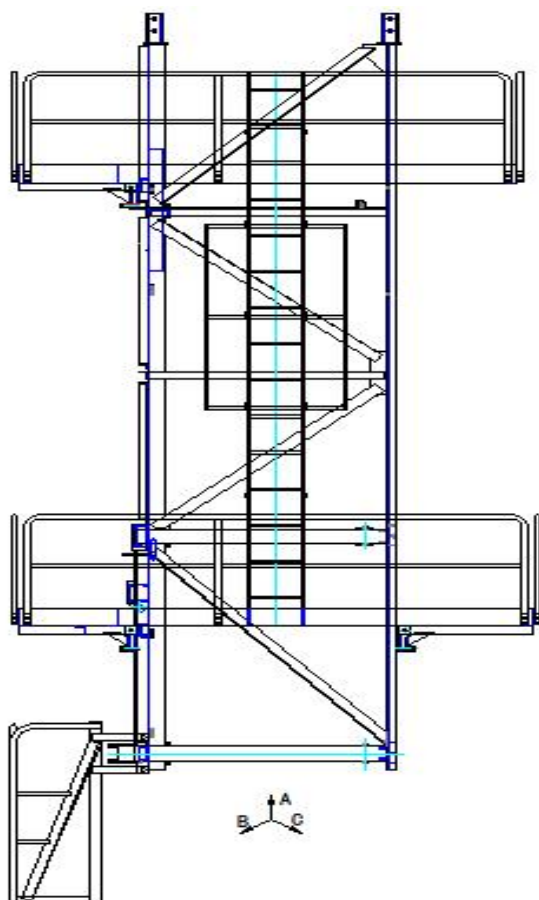

	A	B	C	Weight
	mm	mm	mm	Kg
<b>Climbing Cage Assembly</b>	3585	3585	6785	3405
<b>Skeleton</b>	2320	2100	6785	1760
<b>Jacking Beam</b>	1655	130	579	257
<b>Hydraulic System</b>				600



## Slewing Assembly

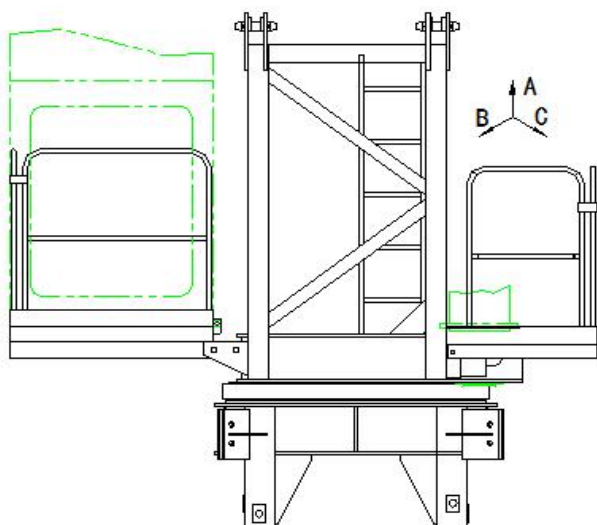

	A	B	C	Weight
				<b>Kg</b>
<b>Slewing assembly</b>	<b>2515</b>	<b>3830</b>	<b>2600</b>	<b>4830</b>
<b>Under turntable</b>	<b>2515</b>	<b>3730</b>	<b>1460</b>	<b>1500</b>
<b>Upper Turntable</b>	<b>1838</b>	<b>1838</b>	<b>1010</b>	<b>1400</b>
<b>Operator cabin</b>				<b>500</b>
<b>Slewing Mechanism</b>				<b>400</b>
<b>Slewing ring</b>				<b>400</b>

## Counter jib

	Counter skeletonI	Lever	Electric control box	Hoisting Mechanism	Assembly
<b>A</b>	<b>6835</b>	<b>5755</b>			<b>9315</b>
<b>B</b>	<b>520</b>	<b>595</b>	/	/	<b>1475</b>
<b>C</b>	<b>1197</b>	<b>2220</b>			<b>2220</b>
<b>Kg</b>	<b>689</b>	<b>826</b>	<b>182</b>	<b>1180</b>	<b>3246</b>

# Lifting

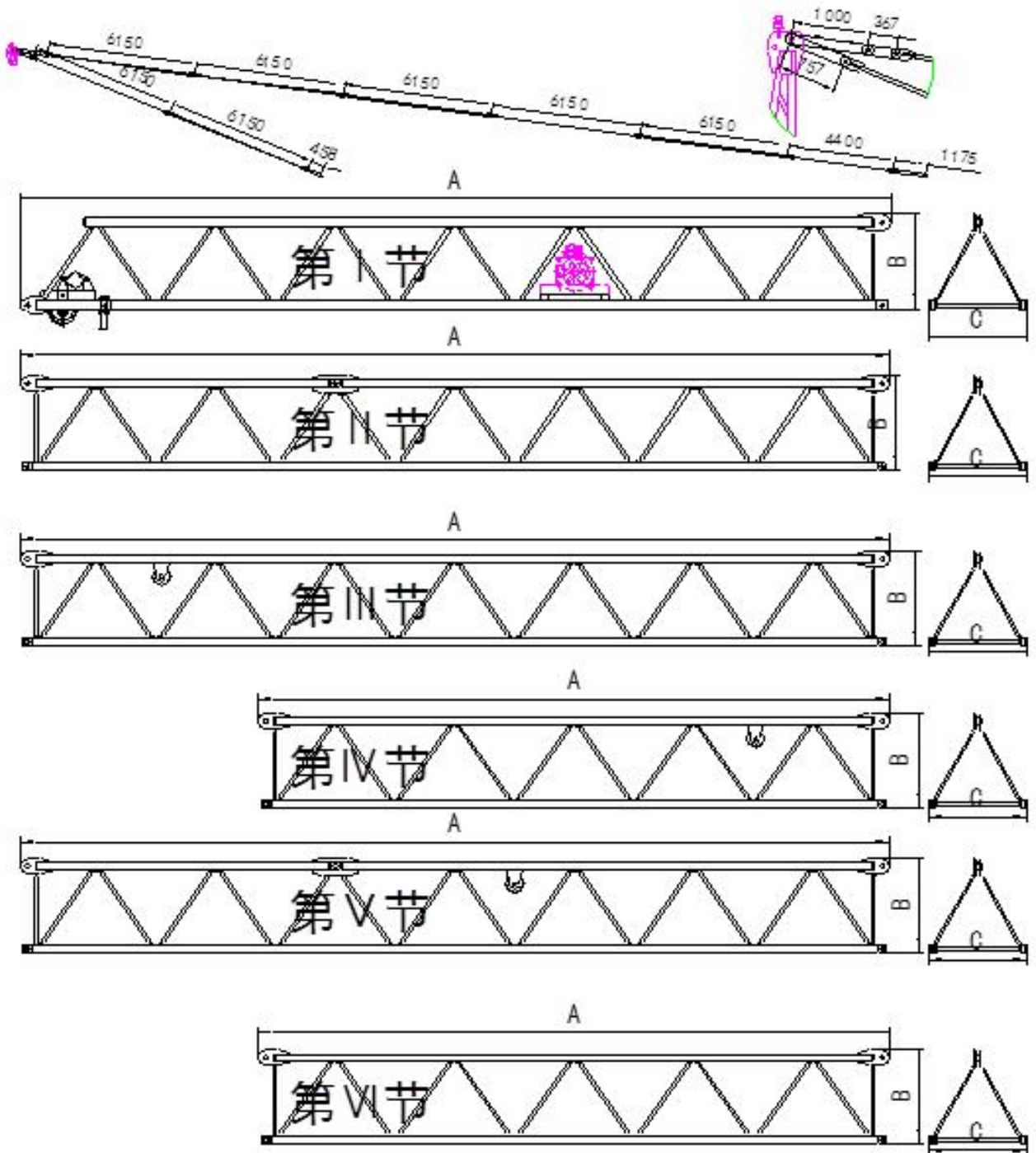





---

## DAHAN Introduction

Dahan Construction Machinery (Group) is a large-scale enterprise group in Chinese construction machinery industry, specializing in the production of "tower cranes" and "construction elevators", with registered capital of 20 million US Dollars, integrating research, development, production, sales, service and finance.

Founded in November, 2000, after 18 years of rapid development, at present, the annual production capacity was over 13,000 sets and become the leading brand in tower crane and elevator industry in China.

The head office of the group is located in Hi-tech Development Zone, Jinan, China, with 3,000 m<sup>2</sup> workplaces. The production bases are separately located in Mingshui Economic Development Zone of Jinan City, Foshan of Guangzhong Province, Yiyang of Hunan Province, with total area of over 300,000 m<sup>2</sup>. At present the group has 8 production bases, 7 operation center, 8 sales companies, one finance lease company and one import & export company.

Talent strategy is the core competitiveness of Dahan Construction Machinery. Dahan has 2300 employees, and 37 persons of them are cutting-edge technical talents, including drafters of national standard of domestic tower crane industry, engineers of implementing earliest FEM calculation of China, and professionals of design calculation and manufacturing technique. Besides, the group also have more than 600 professional personnels of other aspects like sales, management, financing, etc..

Science and technology are primary productive forces. Dahan owns 82 national technology patents (including 5 invention patent. In 2013 the group won the "high-tech enterprise" title, joined the Chinese Hoisting Machinery Standardization Technical Committee, and participated in revision of national standard (GB13752) of tower crane.

At present, the company has imported more than 100 robots of Panasonic and ABB company from Japan and Sweden separately, and owns 12 sets of automatic spraying lines, more than 1000 sets of large plasma cutting machines, CNC drilling machines, milling machines, lathes, boring machines, welding machine and other special tools and equipment. Through advanced equipment, automated assembly line, Dahan can ensure quality of products in the aspect of production technology. Besides, Dahan also build strategic partnership and matching supply cooperation with world-class enterprises such as Baosteel, Ansteel, Dezhou Sheng Jian, Rothe Erde, SIEMENS, Zhejiang Sanmen, France Schneider, etc., to ensure fist class quality of products in the aspect of purchasing of raw material and spare parts.

Now the group has achieved complete coverage of four major series, i.e., top kit tower crane, flat-top tower crane, luffing boom tower crane, and construction hoist, with over 30 types and more than 60 models. Till 2019, Dahan had built sales teams of 2000 persons, and nearly 1000 sales outlets in domestic market, and sold nearly 50,000 Dahan tower cranes to 32 provinces, direct-controlled municipalities, and autonomous region, and exported products to over 50 countries and districts.



In 2012, Dahan established the joint venture, Zhongkang International Financial Leasing Co., Ltd in Binhai New Area, Tianjin City, with 50 million dollars registered capital, to effectively provide clients financing solutions, aiming to achieve the transition of sales modes from “Products supply” to “Supply of products and comprehensive financing service”.

Along with internationalization and implementation of international branding strategy, Dahan Construction Machinery (Group) has developed to be a professional, mature, healthy and highly reliable manufacturer and service provider of tower cranes and construction hoists, and will stand on the top of world’s construction machinery industry with a fire-new image.